

Standard type contact gap is 1mm. Please consult us if you need more than 1mm contact gap.

<http://panasonic-denko.co.jp/ac/e/service/environment>

FEATURES

- High precision as a result of designing ideal spring by using computer analysis
O.P. 14.7±0.4mm
- Reliable design with shock resistance min. 980 m/s²
- High inrush resistance 160A
- Wide variety of contact ratings and terminal types
- UL/C-UL, ENEC/VDE approved

TYPICAL APPLICATION

- Home appliances
- Vending machines
- Amusement and communication equipment
- Copies
- General industrial machines

About Cd-free contacts

We have introduced cadmium-free type products to reduce material which is not good for our environment. (The suffix "N" denotes such part.) Please replace parts containing cadmium with Cd-free products and evaluate them with your actual application before use because the life of a relay depends on the contact material and load. (Note: The suffix "N" is required only for 11 A and 16 A type. 0.1 A and 6 A type are originally cadmium free and the suffix "N" is not required.)

CONSTRUCTION

1. Silver alloy contact

2. Gold clad contact

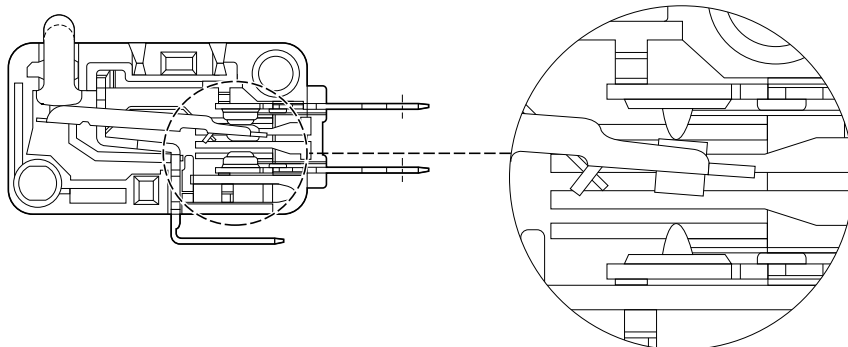

CONTACT ARRANGEMENT

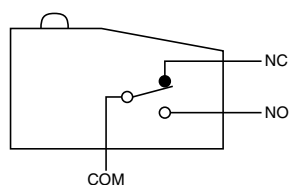

TERMINALS

.187 Quick-connect terminal
.187 Quick-connect/solder terminal
 Bottom COM terminal

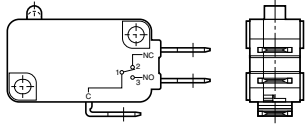

Side COM terminal

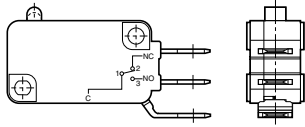

Dimensions
.187 Quick-connect terminal

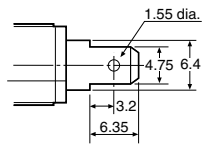

Dimensions
.187 Quick-connect/solder terminal

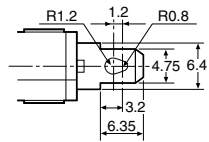

.250 Quick-connect terminal
 Bottom COM terminal

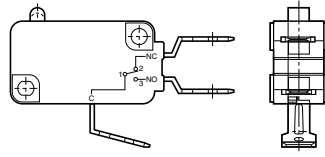

Side COM terminal

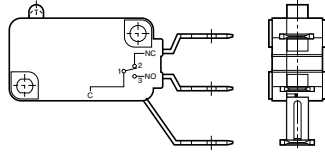

Dimensions

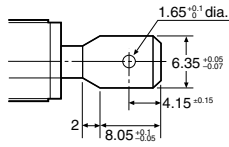

OPERATION FORCE CHART

7th digit of Part Number/Actuator	Operation Force, Max. by actuator				
	3	4	5	6	7
Pin plunger	0.49N	0.98N	1.96N	2.94N	3.92N
Short hinge lever	0.59N	1.08N	2.16N	3.14N	4.12N
Hinge lever	0.29N	0.59N	1.18N	1.77N	2.35N
Long hinge lever	0.15N	0.29N	0.59N	0.88N	1.18N
Simulated roller lever	0.29N	0.59N	1.18N	1.77N	2.35N
Short roller lever	0.59N	1.08N	2.16N	3.14N	4.12N
Roller lever	0.29N	0.59N	1.18N	1.77N	2.35N

ORDERING INFORMATION

0.1A type

Ex. AM5 0 0 1 0 C 5 3

Type of switch	Contact rating	Terminals	Actuators	Terminals	Operating force by pin plunger (max.)	Agency standard
AM5: QV switch	00: 0.1 A (Gold clad)	1: Bottom COM, SPDT 2: Bottom COM, SPST-NC 3: Bottom COM, SPST-NO 4: Side COM, SPDT 5: Side COM, SPST-NC 6: Side COM, SPST-NO	0: Pin plunger 1: Short hinge lever 2: Hinge lever 3: Long hinge lever 4: Simulated roller lever 5: Short roller lever 6: Roller lever	A: .187 Quick-connect/solder terminal C: .187 Quick-connect terminal	3: 0.49 N 4: 0.98 N 5: 1.96 N	3: UL/C-UL rated, ENEC/VDE approved

Remarks: 1. Not every combination is available. Please refer to the table, "PRODUCT TYPES".
2. Please refer to the Standard Chart regarding Agency Standard

6A type

Ex. AM5 0 6 1 0 C 5 3

Type of switch	Contact rating	Terminals	Actuators	Terminals	Operating force by pin plunger (max.)	Agency standard
AM5: QV switch	06: 6 A (Silver alloy)	1: Bottom COM, SPDT 2: Bottom COM, SPST-NC 3: Bottom COM, SPST-NO 4: Side COM, SPDT 5: Side COM, SPST-NC 6: Side COM, SPST-NO	0: Pin plunger 1: Short hinge lever 2: Hinge lever 3: Long hinge lever 4: Simulated roller lever 5: Short roller lever 6: Roller lever	A: .187 Quick-connect/solder terminal C: .187 Quick-connect terminal	3: 0.49 N	3: UL/C-UL rated, ENEC/VDE approved

Remarks: 1. Not every combination is available. Please refer to the table, "PRODUCT TYPES".
2. Please refer to the Standard Chart regarding Agency Standard

11A type

Ex. AM5 1 1 1 0 C 4 3 N

Type of switch	Contact rating	Terminals	Actuators	Terminals	Operating force by pin plunger (max.)	Agency standard	Contact
AM5: QV switch	11: 11 A (Silver alloy)	1: Bottom COM, SPDT 2: Bottom COM, SPST-NC 3: Bottom COM, SPST-NO 4: Side COM, SPDT 5: Side COM, SPST-NC 6: Side COM, SPST-NO	0: Pin plunger 1: Short hinge lever 2: Hinge lever 3: Long hinge lever 4: Simulated roller lever 5: Short roller lever 6: Roller lever	A: .187 Quick-connect/solder terminal C: .187 Quick-connect terminal D: .250 Quick-connect terminal	4: 0.98 N	3: UL/C-UL rated, ENEC/VDE approved	N: Cadmium free

Remarks: 1. Not every combination is available. Please refer to the table, "PRODUCT TYPES".
2. Please refer to the Standard Chart regarding Agency Standard

16A type

Ex. AM5 1 6 1 0 C 5 3 N

Type of switch	Contact rating	Terminals	Actuators	Terminals	Operating force by pin plunger (max.)	Agency standard	Contact
AM5: QV switch	16: 16 A (Silver alloy)	1: Bottom COM, SPDT 2: Bottom COM, SPST-NC 3: Bottom COM, SPST-NO 4: Side COM, SPDT 5: Side COM, SPST-NC 6: Side COM, SPST-NO	0: Pin plunger 1: Short hinge lever 2: Hinge lever 3: Long hinge lever 4: Simulated roller lever 5: Short roller lever 6: Roller lever	A: .187 Quick-connect/solder terminal C: .187 Quick-connect terminal D: .250 Quick-connect terminal	5: 1.96 N 6: 2.94 N 7: 3.92 N	3: UL/C-UL rated, ENEC/VDE approved	N: Cadmium free

Remarks: 1. Not every combination is available. Please refer to the table, "PRODUCT TYPES".
2. Please refer to the Standard Chart regarding Agency Standard

PRODUCT TYPES**0.1A type (Gold clad contact)**

.187 Quick-connect terminal

1) Bottom COM terminal

Actuator	Operating force, Max.	Contact arrangement		
		SPDT	SPST-NC	SPST-NO
Pin plunger	0.49N	AM50010C33	AM50020C33	AM50030C33
	0.98N	AM50010C43	AM50020C43	AM50030C43
	1.96N	AM50010C53	AM50020C53	AM50030C53
Short hinge lever	0.59N	AM50011C33	AM50021C33	AM50031C33
	1.08N	AM50011C43	AM50021C43	AM50031C43
	2.16N	AM50011C53	AM50021C53	AM50031C53
Hinge lever	0.29N	AM50012C33	AM50022C33	AM50032C33
	0.59N	AM50012C43	AM50022C43	AM50032C43
	1.18N	AM50012C53	AM50022C53	AM50032C53
Long hinge lever	0.15N	AM50013C33	AM50023C33	AM50033C33
	0.29N	AM50013C43	AM50023C43	AM50033C43
	0.59N	AM50013C53	AM50023C53	AM50033C53
Simulated roller lever	0.29N	AM50014C33	AM50024C33	AM50034C33
	0.59N	AM50014C43	AM50024C43	AM50034C43
	1.18N	AM50014C53	AM50024C53	AM50034C53
Short roller lever	0.59N	AM50015C33	AM50025C33	AM50035C33
	1.08N	AM50015C43	AM50025C43	AM50035C43
	2.16N	AM50015C53	AM50025C53	AM50035C53
Roller lever	0.29N	AM50016C33	AM50026C33	AM50036C33
	0.59N	AM50016C43	AM50026C43	AM50036C43
	1.18N	AM50016C53	AM50026C53	AM50036C53

2-1) Side COM terminal

Actuator	Operating force, Max.	Contact arrangement		
		SPDT	SPST-NC	SPST-NO
Pin plunger	0.49N	AM50040C33	AM50050C33	AM50060C33
	0.98N	AM50040C43	AM50050C43	AM50060C43
	1.96N	AM50040C53	AM50050C53	AM50060C53
Short hinge lever	0.59N	AM50041C33	AM50051C33	AM50061C33
	1.08N	AM50041C43	AM50051C43	AM50061C43
	2.16N	AM50041C53	AM50051C53	AM50061C53
Hinge lever	0.29N	AM50042C33	AM50052C33	AM50062C33
	0.59N	AM50042C43	AM50052C43	AM50062C43
	1.18N	AM50042C53	AM50052C53	AM50062C53
Long hinge lever	0.15N	AM50043C33	AM50053C33	AM50063C33
	0.29N	AM50043C43	AM50053C43	AM50063C43
	0.59N	AM50043C53	AM50053C53	AM50063C53
Simulated roller lever	0.29N	AM50044C33	AM50054C33	AM50064C33
	0.59N	AM50044C43	AM50054C43	AM50064C43
	1.18N	AM50044C53	AM50054C53	AM50064C53
Short roller lever	0.59N	AM50045C33	AM50055C33	AM50065C33
	1.08N	AM50045C43	AM50055C43	AM50065C43
	2.16N	AM50045C53	AM50055C53	AM50065C53
Roller lever	0.29N	AM50046C33	AM50056C33	AM50066C33
	0.59N	AM50046C43	AM50056C43	AM50066C43
	1.18N	AM50046C53	AM50056C53	AM50066C53

6A type (Silver alloy contact)

.187 Quick-connect terminal

1) Bottom COM terminal

Actuator	Operating force, Max.	Contact arrangement	Contact arrangement	
		SPDT	SPST-NC	SPST-NO
Pin plunger	0.49N	AM50610C33	AM50620C33	AM50630C33
Short hinge lever	0.59N	AM50611C33	AM50621C33	AM50631C33
Hinge lever	0.29N	AM50612C33	AM50622C33	AM50632C33
Long hinge lever	0.15N	AM50613C33	AM50623C33	AM50633C33
Simulated roller lever	0.29N	AM50614C33	AM50624C33	AM50634C33
Short roller lever	0.59N	AM50615C33	AM50625C33	AM50635C33
Roller lever	0.29N	AM50616C33	AM50626C33	AM50636C33

2-1) Side COM terminal

Actuator	Operating force, Max.	Contact arrangement	Contact arrangement	
		SPDT	SPST-NC	SPST-NO
Pin plunger	0.49N	AM50640C33	AM50650C33	AM50660C33
Short hinge lever	0.59N	AM50641C33	AM50651C33	AM50661C33
Hinge lever	0.29N	AM50642C33	AM50652C33	AM50662C33
Long hinge lever	0.15N	AM50643C33	AM50653C33	AM50663C33
Simulated roller lever	0.29N	AM50644C33	AM50654C33	AM50664C33
Short roller lever	0.59N	AM50645C33	AM50655C33	AM50665C33
Roller lever	0.29N	AM50646C33	AM50656C33	AM50666C33

Remarks: Also .187 Quick-connect/solder terminal is available. When ordering, change the eighth digit of part number C to A.

<ex.> .187 Quick-connect terminal .187 Quick-connect/solder terminal
 AM50610C4 → AM50610A4

11A type (Silver alloy contact)

.187 Quick-connect terminal

1) Bottom COM terminal

Actuator	Operating force, Max.	Contact arrangement	Contact arrangement	
		SPDT	SPST-NC	SPST-NO
Pin plunger	0.98N	AM51110C43N	AM51120C43N	AM51130C43N
Short hinge lever	1.08N	AM51111C43N	AM51121C43N	AM51131C43N
Hinge lever	0.59N	AM51112C43N	AM51122C43N	AM51132C43N
Long hinge lever	0.29N	AM51113C43N	AM51123C43N	AM51133C43N
Simulated roller lever	0.59N	AM51114C43N	AM51124C43N	AM51134C43N
Short roller lever	1.08N	AM51115C43N	AM51125C43N	AM51135C43N
Roller lever	0.59N	AM51116C43N	AM51126C43N	AM51136C43N

2-1) Side COM terminal

Actuator	Operating force, Max.	Contact arrangement	Contact arrangement	
		SPDT	SPST-NC	SPST-NO
Pin plunger	0.98N	AM51140C43N	AM51150C43N	AM51160C43N
Short hinge lever	1.08N	AM51141C43N	AM51151C43N	AM51161C43N
Hinge lever	0.59N	AM51142C43N	AM51152C43N	AM51162C43N
Long hinge lever	0.29N	AM51143C43N	AM51153C43N	AM51163C43N
Simulated roller lever	0.59N	AM51144C43N	AM51154C43N	AM51164C43N
Short roller lever	1.08N	AM51145C43N	AM51155C43N	AM51165C43N
Roller lever	0.59N	AM51146C43N	AM51156C43N	AM51166C43N

Remarks: 1. Also .187 Quick-connect/solder terminal is available. When ordering, change the eighth digit of part number C to A.

<ex.> .187 Quick-connect terminal .187 Quick-connect/solder terminal
 AM51110C4 → AM51110A4

2. .250 Quick-connect terminal is available. When ordering, change the eighth digit of part number C to D.

<ex.> .187 Quick-connect terminal .250 Quick-connect terminal
 AM51110C4 → AM51110D4

AM5

16A type (Silver alloy contact)

.187 Quick-connect terminal

1) Bottom COM terminal

Actuator	Operating force, Max.	Contact arrangement	Contact arrangement	
		SPDT	SPST-NC	SPST-NO
Pin plunger	1.96N	AM51610C53N	AM51620C53N	AM51630C53N
	2.94N	AM51610C63N	AM51620C63N	AM51630C63N
	3.92N	AM51610C73N	AM51620C73N	AM51630C73N
Short hinge lever	2.16N	AM51611C53N	AM51621C53N	AM51631C53N
	3.14N	AM51611C63N	AM51621C63N	AM51631C63N
	4.12N	AM51611C73N	AM51621C73N	AM51631C73N
Hinge lever	1.18N	AM51612C53N	AM51622C53N	AM51632C53N
	1.77N	AM51612C63N	AM51622C63N	AM51632C63N
	2.35N	AM51612C73N	AM51622C73N	AM51632C73N
Long hinge lever	0.59N	AM51613C53N	AM51623C53N	AM51633C53N
	0.88N	AM51613C63N	AM51623C63N	AM51633C63N
	1.18N	AM51613C73N	AM51623C73N	AM51633C73N
Simulated roller lever	1.18N	AM51614C53N	AM51624C53N	AM51634C53N
	1.77N	AM51614C63N	AM51624C63N	AM51634C63N
	2.35N	AM51614C73N	AM51624C73N	AM51634C73N
Short roller lever	1.18N	AM51615C53N	AM51625C53N	AM51635C53N
	3.14N	AM51615C63N	AM51625C63N	AM51635C63N
	4.12N	AM51615C73N	AM51625C73N	AM51635C73N
Roller lever	1.18N	AM51616C53N	AM51626C53N	AM51636C53N
	1.77N	AM51616C63N	AM51626C63N	AM51636C63N
	2.35N	AM51616C73N	AM51626C73N	AM51636C73N

2-1) Side COM terminal

Actuator	Operating force, Max.	Contact arrangement	Contact arrangement	
		SPDT	SPST-NC	SPST-NO
Pin plunger	1.96N	AM51640C53N	AM51650C53N	AM51660C53N
	2.94N	AM51640C63N	AM51650C63N	AM51660C63N
	3.92N	AM51640C73N	AM51650C73N	AM51660C73N
Short hinge lever	2.16N	AM51641C53N	AM51651C53N	AM51661C53N
	3.14N	AM51641C63N	AM51651C63N	AM51661C63N
	4.12N	AM51641C73N	AM51651C73N	AM51661C73N
Hinge lever	1.18N	AM51642C53N	AM51652C53N	AM51662C53N
	1.77N	AM51642C63N	AM51652C63N	AM51662C63N
	2.35N	AM51642C73N	AM51652C73N	AM51662C73N
Long hinge lever	0.59N	AM51643C53N	AM51653C53N	AM51663C53N
	0.88N	AM51643C63N	AM51653C63N	AM51663C63N
	1.18N	AM51643C73N	AM51653C73N	AM51663C73N
Simulated roller lever	1.18N	AM51644C53N	AM51654C53N	AM51664C53N
	1.77N	AM51644C63N	AM51654C63N	AM51664C63N
	2.35N	AM51644C73N	AM51654C73N	AM51664C73N
Short roller lever	2.16N	AM51645C53N	AM51655C53N	AM51665C53N
	3.14N	AM51645C63N	AM51655C63N	AM51665C63N
	4.12N	AM51645C73N	AM51655C73N	AM51665C73N
Roller lever	1.18N	AM51646C53N	AM51656C53N	AM51666C53N
	1.77N	AM51646C63N	AM51656C63N	AM51666C63N
	2.35N	AM51646C73N	AM51656C73N	AM51666C73N

Remarks: 1. .187 Quick-connect/solder terminal is available. When ordering, change the eighth digit of part number C to A.

<ex.> .187 Quick-connect terminal .187 Quick-connect/solder terminal
AM51610C5 → AM51610A5

2. .250 Quick-connect terminal is available. When ordering, change the eighth digit of part number C to D.

<ex.> .187 Quick-connect terminal .250 Quick-connect terminal
AM51610C5 → AM51610D5

DATA

Gold-clad type

Range of low-level current voltage

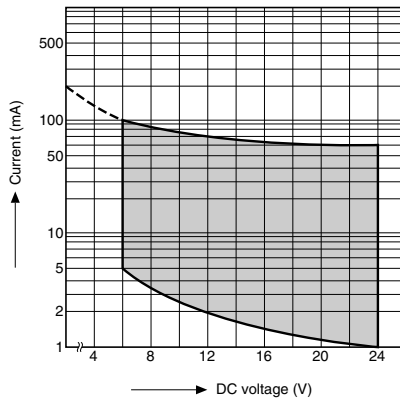
**SPECIFICATIONS****1. Contact rating**

Type		Voltage	Resistive load (cos=1)	Inductive load (cos nearly equal 0.6 to 0.7)
Gold clad contact	0.1A type	250V AC	0.1A	0.1A
		125V AC	0.1A	0.1A
		30V DC	0.1A	0.1A
Silver alloy contact	6A type	250V AC	6A	3A
		125V AC	6A	3A
		125V DC	0.5A	0.5A
	11A type	250V AC	11A	6A
		125V AC	11A	6A
		125V DC	0.6A	0.6A
16A type	250V AC	16A	10A	
	125V AC	16A	10A	
	125V DC	0.6A	0.6A	
Gold clad contact for low level circuit		6V DC	5mA	—
		12V DC	2mA	—
		24V DC	1mA	—

Remark: The inductive load for DC should have a time constant of 7 ms or less.

2. Characteristics

Type		16, 11, 6A type (Silver alloy)	0.1A type (Gold clad)
Expected life (min.)	Mechanical	10 ⁷ operations (at 60 cpm)	
	Electrical	10 ⁵ Operations (at rated load 20 cpm)	10 ⁵ operations (at rated load) 2 × 10 ⁶ operations (at low-level circuit rating)
Insulation resistance		100MΩ (at 500V DC)	
Dielectric strength	Between terminals	1,000Vrms for 1 min.	
	Between terminals and other exposed metal parts	2,000Vrms for 1 min.	
	Between terminals and ground	2,000Vrms for 1 min.	
Contact resistance (initial)		50mΩ (by voltage drop at 1A 6 to 8V DC)	50mΩ (by voltage drop at 0.1A 6 to 8V DC)
Vibration resistance (by pin plunger)		10 to 55Hz at simple amplitude of 0.75mm (Contact opening: max. 1msec.)	
Shock resistance (by pin plunger) (contact opening: max. 1msec.)		O.F. 0.49N max. type Min. 98m/s ² O.F. 0.98N max. type Min. 196m/s ² O.F. 1.96N to 3.92N max. type Min. 294m/s ²	O.F. 0.15N to 0.49N max. type Min. 98m/s ² O.F. 0.98N max. type Min. 196m/s ² O.F. 1.96N max. type Min. 294m/s ²
Allowable operating speed		0.1 to 1,000mm/sec. (at pin plunger)	
Maximum operating cycle rate		600cpm	
Ambient temperature		-25 to +105°C (Not freezing below 0°C)	
Weight		6.3g	

AM5

3. Operating characteristics

Pin plunger

7th digit of part No.	3	4	5	6	7
Operating force, max.	0.49N	0.98N	1.96N	2.94N	3.92N
Release force, min.	0.12N	0.25N	0.49N	0.74N	0.98N
Pretravel, max. mm	1.4				
Movement differential, max. mm	0.4				
Overtravel, min. mm	1.0				
Operating position mm	14.7±0.4				

Short hinge lever

7th digit of part No.	3	4	5	6	7
Operating force, max.	0.59N	1.08N	2.16N	3.14N	4.12N
Release force, min.	0.098N	0.20N	0.39N	0.59N	0.78N
Pretravel, max. mm	1.6				
Movement differential, max. mm	0.5				
Overtravel, min. mm	0.9				
Operating position mm	15.3±0.5				

Hinge lever

7th digit of part No.	3	4	5	6	7
Operating force, max.	0.29N	0.59N	1.18N	1.77N	2.35N
Release force, min.	0.049N	0.098N	0.20N	0.29N	0.39N
Pretravel, max. mm	3.2				
Movement differential, max. mm	1.0				
Overtravel, min. mm	1.4				
Operating position mm	15.3±1.0				

Long hinge lever

7th digit of part No.	3	4	5	6	7
Operating force, max.	0.15N	0.29N	0.59N	0.88N	1.18N
Release force, min.	0.025N	0.049N	0.098N	0.15N	0.20N
Pretravel, max. mm	7.5				
Movement differential, max. mm	2.0				
Overtravel, min. mm	2.2				
Operating position mm	15.3±2.6				

Simulated roller lever

7th digit of part No.	3	4	5	6	7
Operating force, max.	0.29N	0.59N	1.18N	1.77N	2.35N
Release force, min.	0.049N	0.098N	0.20N	0.29N	0.39N
Pretravel, max. mm	3.2				
Movement differential, max. mm	1.0				
Overtravel, min. mm	1.4				
Operating position mm	18.5±1.0				

Short roller lever

7th digit of part No.	3	4	5	6	7
Operating force, max.	0.59N	1.08N	2.16N	3.14N	4.12N
Release force, min.	0.098N	0.20N	0.39N	0.59N	0.78N
Pretravel, max. mm	1.6				
Movement differential, max. mm	0.5				
Overtravel, min. mm	0.9				
Operating position mm	20.7±0.5				

Roller lever

7th digit of part No.	3	4	5	6	7
Operating force, max.	0.29N	0.59N	1.18N	1.77N	2.35N
Release force, min.	0.049N	0.098N	0.20N	0.29N	0.39N
Pretravel, max. mm	3.2				
Movement differential, max. mm	1.0				
Overtravel, min. mm	1.4				
Operating position mm	20.7±1.0				

DIMENSIONS

1. Pin plunger
Bottom COM terminal



.187 Quick-connect terminal

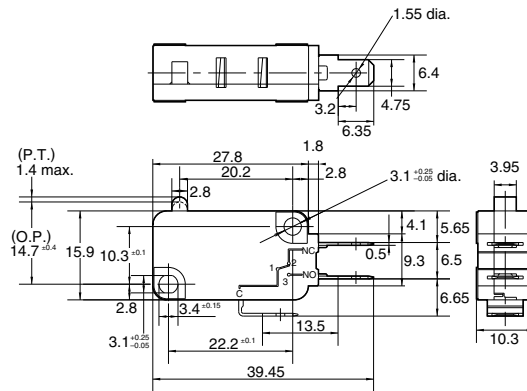

.250 Quick-connect terminal

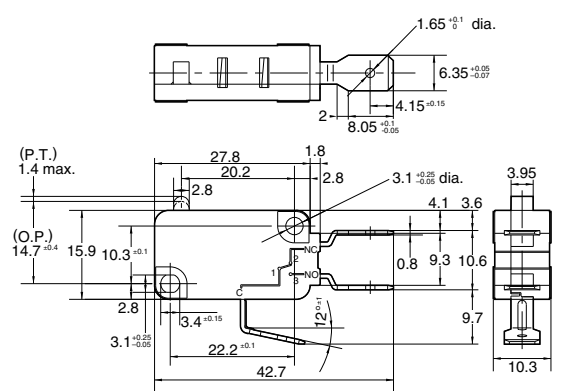

Side COM terminal



.187 Quick-connect terminal

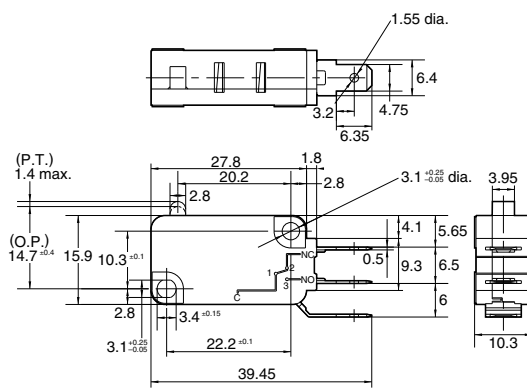

.250 Quick-connect terminal

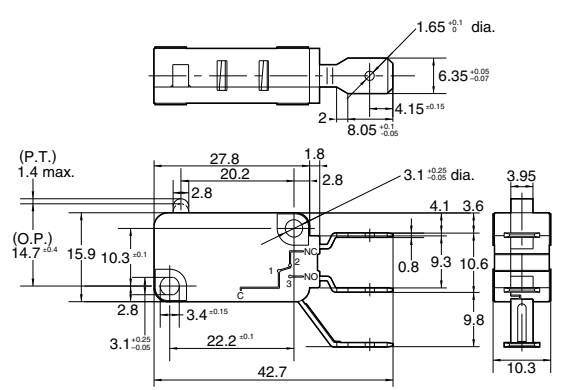

2. Short hinge lever

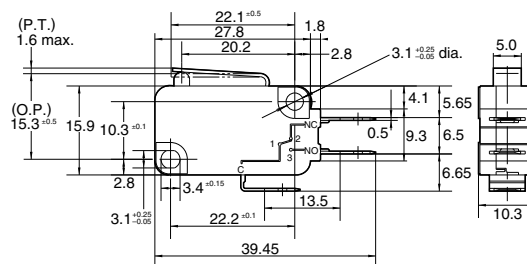
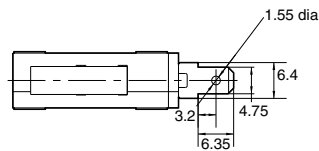

The dimensions other than drawn above are same as pin plunger type.

AM5

3. Hinge lever

mm General tolerance: ± 0.25

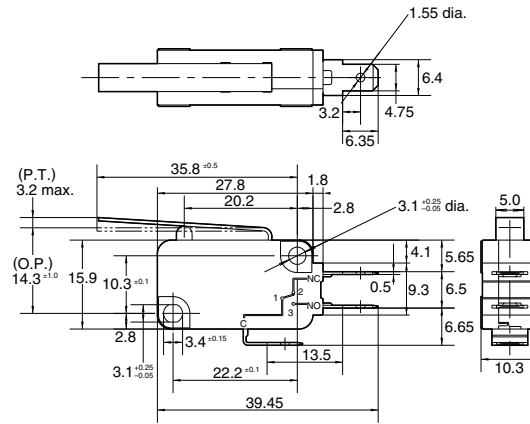

The dimensions other than drawn above are same as pin plunger type.

4. Long hinge lever

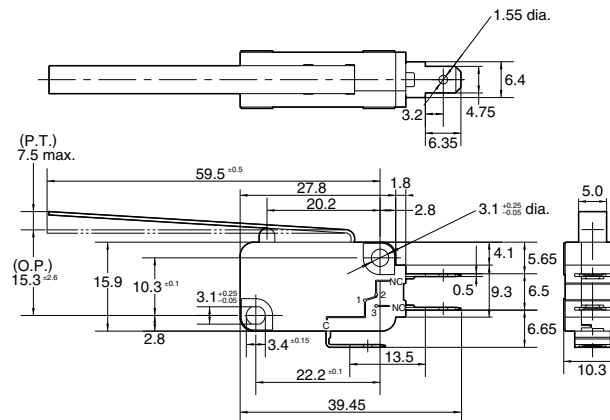

The dimensions other than drawn above are same as pin plunger type.

5. Simulated roller lever

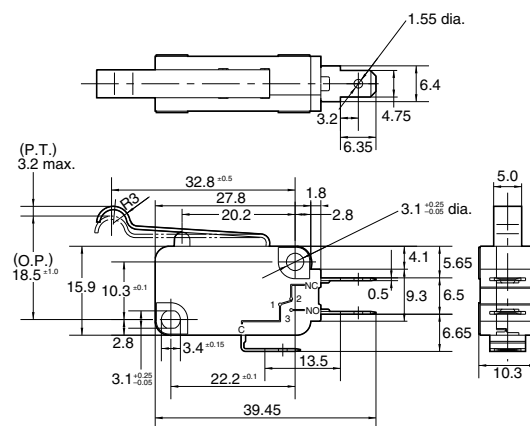

The dimensions other than drawn above are same as pin plunger type.

6. Short roller lever

mm General tolerance: ± 0.25

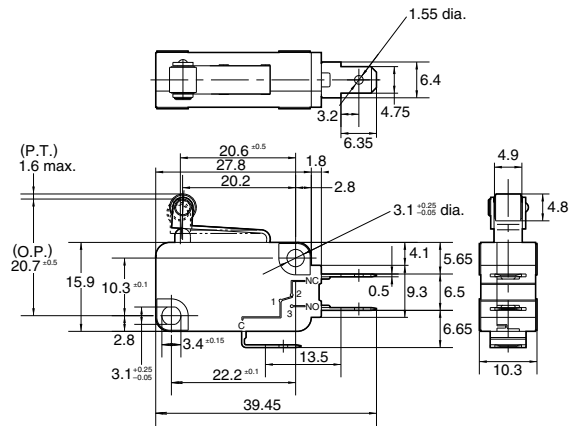

The dimensions other than drawn above are same as pin plunger type.

7. Hinge Roller lever

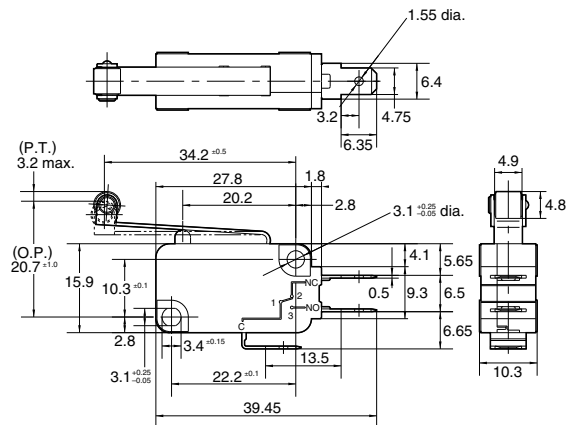

The dimensions other than drawn above are same as pin plunger type.

NOTES

1. Fastening of the switch body

- 1) Use flat filister head M3 screws to mount switches with less than a 0.49 N-m torque. Use of screws washers or adhesive lock is recommended to prevent loosening of the screws.
- 2) Check insulation distance between ground and each terminal.
- 3) When the operation object is in the free position, force should not be applied directly to the actuator or pin plunger. Also force should be applied to the pin plunger from vertical direction to the switch.
- 4) The standard value of overtravel should be the range of 70% to 100% of the rated O.T. value.

2. Soldering operations

Soldering should be accomplished in less than 5 seconds, with a 60 watt iron. Care should be taken not to apply force to the terminal during soldering.

3. Variance of operating characteristics

When specifying the switch, allow +20% to the listed operating and release forces.

4. Environment

Avoid using the switches in the following conditions;

- In corrosive gases, such as silicon gas
- In a dusty environment

5. For switching of inductive loads (relays, solenoids, etc.)

- 1) In order to prevent damage to contacts due to the occurrence of arcing, an arc absorbing circuit should be applied.
- 2) Care should be taken that occurrence in AC load possibly shorten the expected life.

6. Please assure the quality and reliability of the switch under the actual service condition.

7. It is recommended to use Gold clad contact type in use of low-level circuit rating.

8. Cover and body are press-fitted. Once it is taken apart, it may cause change of characteristics.

9. Cover and body are press-fitted. Once it is taken apart, it may cause change of characteristics.

USE OF CONNECTOR

The .187 Quick-connect terminal and .250 Quick-connect terminal accept the all kinds of 1 polarity connectors and the "Positive Lock" connectors

Please contact the manufacturers directly.

• receptacle terminal

.250 series

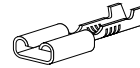

.187 series

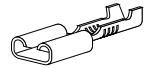

• "Positive Lock" connector. (equipped with the lock construction of low insertion type)

.187 type
(1 polarity)

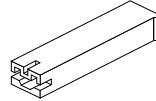

.187 type
(2 polarities)

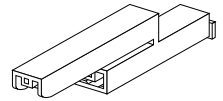

.250 type
(1 polarity)

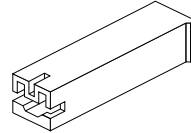

.187 type
(3 polarities)

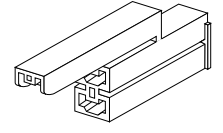



**MINIATURE SWITCHES
WITH HIGH PRECISION**
(Contact gap:
more than 1mm type)

**AM5 (QV)
SWITCHES**



- **Conforms with the IEC950 standards for secondary circuit insulation distance. Assures a contact gap of at least 1mm**
- **Can handle high-capacity loads on the secondary side that S-type size switches cannot**
- **High inrush and hard impacts resistant**
- **Excellent operating position precision**
- **UL/CSA/VDE/SEMKO/TÜV approved**

We have introduced Cadmium free type products to reduce the material which is not good for our environment. (The suffix "N" should be added to the part number.) (Note: The Suffix "N" is required only for 11A and 16A type only. 0.1A and 6A type are originally Cadmium free and the suffix "N" is not required.)

If you are still using the Cadmium containing parts, which don't have "N" on the suffix of the part number, please use Cadmium free parts from now on. The life of the Cadmium free parts may be shorter than the Cadmium containing parts based on the load condition, so please evaluate the Cadmium free parts with your actual application before use.

<http://panasonic-denko.co.jp/ac/e/service/environment>

PRODUCT TYPES

Contact rating: 0.1A, 6A, 11A, 16A (250V AC)

Terminal shape: .187 Quick connect terminal, .187 Quick connect/solder terminal

For other specifications, please consult us.

DIMENSIONS AND NOTES

Please refer to Standard QV switches catalog for dimensions and notes.

SPECIFICATIONS

• Contact ratings (0.1 to 16 A)

Voltage	Resistive load ($\cos \phi = 1.0$)				Inductive load ($\cos \phi \cong 0.6$ to 0.7)				
	Type	0.1A	6A	11A	16A	0.1A	6A	11A	16A
250V AC	0.1A	6A	11A	16A	0.1A	3A	6A	10A	
125V AC	0.1A	6A	11A	16A	0.1A	3A	6A	10A	
125V DC	0.1A	0.5A	0.6A	0.6A	0.1A	0.5A	0.6A	0.6A	

• 0.1A type minimum load:

- 6V DC 5mA (Resistive load)
- 12V DC 2mA (Resistive load)
- 24V DC 1mA (Resistive load)

Remark: The inductive load for DC should have a time constant of 7 ms or less.

Please consult us for further information.